

# ICC-ES Evaluation Report

**ESR-2218**

Reissued August 1, 2012

This report is subject to renewal September 1, 2013.

[www.icc-es.org](http://www.icc-es.org) | (800) 423-6587 | (562) 699-0543

A Subsidiary of the International Code Council®

**DIVISION: 07 00 00—THERMAL AND MOISTURE  
PROTECTION**
**Section: 07 42 13—Metal Wall Panels**
**REPORT HOLDER:**

**METL-SPAN, LLC**  
1720 LAKEPOINTE DRIVE, SUITE 101  
LEWISVILLE, TEXAS 75057  
(972) 221-6656

[www.metlspan.com](http://www.metlspan.com)  
[arhakimi@metlspan.com](mailto:arhakimi@metlspan.com)

**EVALUATION SUBJECT:**
**METL-SPAN CF COMPOSITE FOAM WALL PANELS  
(M-S CF)**
**1.0 EVALUATION SCOPE**
**Compliance with the following codes:**

- 2009 *International Building Code*® (2009 IBC)
- 2006 *International Building Code*® (2006 IBC)

**Properties evaluated:**

- Structural
- Fire resistance

**2.0 USES**

The Metl-Span CF composite foam plastic panels (M-S CF) described in this report are used as exterior and interior nonload-bearing wall panels of nonfire-resistance-rated, Type I, II, III, IV (noncombustible) or V building construction. For use as exterior wall panels where noncombustible construction is required, the panels' installation must conform to Section 4.3 of this report.

**3.0 DESCRIPTION**
**3.1 General:**

The M-S CF panels are factory-assembled, metal-faced, sandwich panels with a chemically bonded, continuously foamed-in-place foam plastic core. The panels recognized in this report have identical side joints and liner profiles. The difference between the panels is the exterior fascia skin profile. Three exterior fascia profiles are available: Architectural Flat, Fluted, and Mesa. Panels have model numbers CF-30, CF-36, and CF-42, which correspond to standard 30-, 36- and 42-inch (762, 914 and 1067 mm) widths. The panels are available in thicknesses of 2, 2<sup>1</sup>/<sub>2</sub>,

3, 4, 5 and 6 inches (51, 64, 76, 102, 127, and 152 mm). Maximum panel length is 65 feet (19,812 mm). See Figure 1 for an illustration of the wall panel profiles.

**3.2 Materials:**

**3.2.1 Panel Core:** The core of the wall panels is a polyurethane foam plastic, designated FE-242HD. The cores have a 2.17 pcf (34.7 kg/m<sup>3</sup>) nominal density, and have a flame-spread index of 25 or less and a smoke-developed index of 450 or less when tested in accordance with ASTM E 84. The foam plastic is continuously foamed-in-place into the core of the panel during panel fabrication.

**3.2.2 Panel Skins:** Panel skins are identified as “fascia skin” and “liner skin.” “Fascia skin” is the panel skin material facing the exterior of the building, whereas “liner skin” is the panel skin material facing the interior of the building. The fascia and liner skins can have equal or different thicknesses. The three types of fascia skin profiles are denoted by a single character, as follows:

- A = “Architectural Flat” profile, for wall panels having a maximum width of 36 inches (914 mm).
- F = “Fluted” profile, for wall panels having a maximum width of 42 inches (1067 mm).
- M = “Mesa” profile, for wall panels having a maximum width of 42 inches (1067 mm).

For example, the product designation CF-42-FM-22/26 indicates a composite foam panel that has a 42-inch (1067 mm) panel cover width, a “Fluted” fascia profile and a “Mesa” liner profile, and No. 22 gage [0.030 inch (0.762 mm)] and No. 26 gage [0.019 inch (0.483 mm)] fascia and liner skin steel thicknesses, respectively.

Panel facing material is steel conforming to ASTM A 653 SS (Structural Steel) Grade 33, with Class G 90 galvanization coating, or steel conforming to ASTM A 792 SS Grade 33, with a Class AZ50 galvalume coating. Facing material thickness is No. 26 or No. 22 gage, with an uncoated metal thickness of 0.0190 or 0.0300 inch (0.483 or 0.762 mm), respectively. Finishes applied over the facing material must comply as a Class A finish in accordance with IBC Section 803.1.

**3.2.3 Connections:**

**3.2.3.1 U-Clips:** The U-clips are brackets that are used to fasten the wall panels to supporting framing. The U-Clips are galvanized or stainless steel, and measure 1 inch (25.4 mm) wide by 4 inches (102 mm) long by No. 14 gage [0.068 inch (1.727 mm)]. See Figures 2 and 3 for details of the U-clip and its application.

**3.2.3.2 U-Clip Fasteners:** Screws used to attach the panels to steel supports must be minimum No. 14, self-drilling or self-tapping screws, complying with SAE J78. The screws used with the panels must be sufficiently long to penetrate through the structural supporting member. The fastener connection to the supporting member must be designed to the satisfaction of the code official. The fasteners must be corrosion-resistant.

**3.2.3.3 Expansion Fasteners:** Fab-Lok® FAS/FAC 10-4, 10-8, and 10-12 fasteners are expansion fasteners used to attach the panels to steel supports. The fasteners have three different grip ranges: 0 to  $\frac{1}{4}$  inch (0. to 6.4 mm),  $\frac{1}{4}$  to  $\frac{1}{2}$  inch (6.4 to 12.7 mm), and  $\frac{1}{2}$  to  $\frac{3}{4}$  inch (12.7 to 19 mm), respectively. The fastener connection to the supporting member must be designed to the satisfaction of the code official. The fasteners must be corrosion-resistant.

**3.2.4 Sealants:** Butyl caulk is used for panel joints, and butyl sealant tape is used for trim. The caulk must conform to Federal Specification TT-C-1796A, Type I, Class A. Sealant tape must conform to Federal Specification TT-C-1796A, Type II, Class A. The caulk and tape must be applied to clean and dry surfaces at temperatures as recommended by the caulk and tape manufacturers.

**3.2.5 Flashing:** Flashing material must be corrosion-resistant steel having the same gage as the panel fascia skin.

## 4.0 DESIGN AND INSTALLATION

### 4.1 Design:

An analysis must be submitted to the code official showing that the panel system, including fasteners and structural framing members, provides a complete load path capable of transferring all loads and forces from their point of origin to load-resisting elements. Tables 1 through 12 of this report contain allowable, out-of-plane, transverse, uniform wind loads for the wall panels based on panel stiffness, panel strength (both bending and horizontal shear), and panel connection design. Allowable loads presented in the tables for panels having No. 26 gage skins can be used for panels with No. 24 gage steel skins.

### 4.2 Installation:

Each wall panel must be placed with the panel's longitudinal edge oriented in the vertical or horizontal direction. Individual panels may span one, two, three or more spans. The panels are erected from left to right or right to left, leading with the male edge. See Figure 2 for typical panel layout. The panels must be fastened to structural steel supports by means of U-clip brackets and U-clip fasteners placed in the tongue-and-groove longitudinal side joint of the panels. The structural support members must provide a minimum bearing width of 2.5 inches (64 mm) to the panels. The structural support members and the connection of the panels to the structural support members must be designed to resist the applied forces.

At the end supports, the wall panel clip (U-clip) must be fastened with one fastener. At the intermediate panel supports, the wall panel clip must be fastened with two fasteners. U-Clip fasteners must be as described in Section 3.2.3.2 of this report.

The longitudinal side joints of the panels have a  $\frac{1}{4}$ -inch (6.4 mm) bead of butyl sealant that is either factory- or field-applied into one or both of the grooves of the panels. During erection, the side joints of adjacent panels are interlocked such that there is continuous contact of both panels with the sealant. Erection proceeds along the wall elevation, with the installation of successive panels in

accordance with the published Metl-Span installation guide. Expansion fasteners, as described in Section 3.2.3.3, must be used to attach the liner facing to framing supports as required by the approved structural design. The expansion fasteners must be field-installed in accordance with the installation instructions. See Figure 3 for panel joint details and Figures 2 and 4 for attachment details.

Provided the sealants and application of the sealants are satisfactory to the code official, panels exposed to weather do not require a weather-resistive barrier in accordance with Section 1405 of the IBC when panels are installed with sealant as specified in this section (Section 4.2) and wall openings and penetrations are flashed. Flashing must be placed in accordance with Section 1405.3 of the IBC on both ends of the panels when installation is at the building's base, and at eaves, openings, and horizontal and vertical corners. The flashing is attached to the panels with self-tapping, self-drilling screws or pop rivets in accordance with the published Metl-Span installation guide.

### 4.3 Noncombustible Construction:

Metl-Span CF panels having a 6-inch (152 mm) maximum thickness are permitted to be used in exterior, nonload-bearing, noncombustible, nonfire-resistance-rated, multistory wall construction. Panels must be installed with the panel length oriented vertically or horizontally and be attached to steel framing. Wall stud cavities at floor-to-wall joints must be blocked with 4 lb/ft<sup>3</sup> (64 kg/m<sup>3</sup>) density mineral wool insulation. Wall openings must be protected by placing 4 lb/ft<sup>3</sup> (64 kg/m<sup>3</sup>) mineral wool insulation strips around openings covered with steel having a minimum 0.019-inch (0.48 mm) base-metal thickness mechanically fastened to panels.

## 5.0 CONDITIONS OF USE

The Metl-Span CF Composite foam panels described in this report comply with, or are suitable alternatives to what is specified in, those codes listed in Section 1.0 of this report, subject to the following conditions:

- 5.1** Panels must be installed in accordance with this report and the manufacturer's published installation instructions, a copy of which must be available at the jobsite. In the event of a conflict between this report and the manufacturer's published installation instructions, the more restrictive governs.
- 5.2** Wall panels must be limited to nonload-bearing wall applications.
- 5.3** Remaining portions of the structure, other than Metl-Span wall panels, must be designed and constructed in accordance with the code.
- 5.4** Construction plans, calculations for actual loading conditions and calculations for the connection of the panel to the supporting member must be submitted to the code official for approval.
- 5.5** All construction documents specifying the panels described in this report must comply with the design limitations of this report. Drawings and design details demonstrating that the Metl-Span panels comply with this report must be submitted to the code official at the time of permit application. The drawings and design details must be prepared by a registered design professional where required by the statutes of the jurisdiction in which the project is to be constructed.
- 5.6** The Metl-Span CF panels described in this report have been justified for installation without the thermal barrier required by IBC Section 2603.4.

5.7 The panels must be fabricated by Metl-Span, LLC, at their manufacturing plants located in Lewisville, Texas, and North Las Vegas, Nevada, under a quality control program with inspections by Intertek Testing Services, Inc. (AA-690).

**6.0 EVIDENCE SUBMITTED**

- 6.1 Data in accordance with the ICC-ES Acceptance Criteria for Sandwich Panels (AC04), dated June 2007.
- 6.2 Data in accordance with the ICC-ES Acceptance Criteria for Foam Plastic Insulation (AC12), dated May 2008.

6.3 Reports of testing in accordance with NFPA 285 and NFPA 286.

**7.0 IDENTIFICATION**

Each panel is identified on the edge or on the face with the quality control inspection agency name (Intertek), product name, insulation manufacturer name, and flame-spread and smoke-development ratings. The panel package is labeled with the evaluation report number (ICC-ES ESR-2218), panel thickness, panel width, fascia/liner profile, and fascia/liner facing steel thickness.

**Table 1: Maximum Allowable Wind Pressure for Metl-Span CF Composite Foam Wall Panel<sup>1,2</sup>**

Panel Thickness: 2 inches  
 Panel Width: 30 inches (CF-30) or 36 inches (CF-36)  
 Fascia/Liner Profile: Mesa/Mesa  
 Fascia/Liner Steel Thickness: 26/26

Span (feet)	No of Spans	Allowable Negative and Positive Wind Pressure (psf)							
		Panel Stiffness and Strength		Panel Connection Strength <sup>3</sup>					
		I/180	Strength	Pattern 1		Pattern 2		Pattern 3	
				CF-30	CF-36	CF-30	CF-36	CF-30	CF-36
5	1	93.4	77.2	41.7	34.7	62.3	51.9	84.8	70.7
	2	100.2	68.7	47.5	39.6	71.1	59.2	89.0	74.1
	3	101.4	67.6	48.6	40.5	72.6	60.5	93.3	77.7
6	1	70.6	61.3	34.7	29.0	51.9	43.3	70.7	58.9
	2	79.0	56.1	40.7	33.9	60.8	50.7	72.7	60.6
	3	79.6	55.7	41.1	34.3	61.5	51.3	77.2	64.4
7	1	54.5	55.1	29.8	24.8	44.5	37.1	60.6	50.5
	2	63.9	47.4	35.6	29.7	53.0	44.2	61.3	51.1
	3	64.0	47.3	35.7	29.7	53.3	44.4	65.9	54.9
8	1	42.8	48.2	26.1	21.7	39.0	32.5	53.0	44.2
	2	52.7	40.9	31.4	26.1	45.8	38.2	53.0	44.2
	3	52.3	41.2	31.5	26.2	47.1	39.2	57.5	47.9
9	1	34.1	40.4	23.2	19.3	34.6	28.9	47.1	39.3
	2	44.0	36.0	27.6	23.0	40.3	33.6	46.7	38.9
	3	43.2	36.4	28.2	23.5	42.1	35.1	51.0	42.5
10	1	27.5	32.7	20.8	17.4	31.2	26.0	42.4	35.3
	2	37.2	32.2	24.7	20.6	36.0	30.0	41.7	34.7
	3	36.1	32.7	25.5	21.2	38.1	31.7	45.8	38.2
11	1	22.4	27.0	19.0	15.8	28.3	23.6	38.6	32.1
	2	31.8	29.1	22.3	18.6	32.5	27.1	37.6	31.4
	3	30.4	29.6	23.2	19.4	34.7	28.9	41.6	34.6
12	1	18.5	22.7	17.4	14.5	26.0	21.6	35.3	29.5
	2	27.3	26.5	20.3	16.9	29.7	24.7	34.3	28.6
	3	25.8	27.1	21.4	17.8	31.9	26.6	38.1	31.7

For SI: 1 foot = 305 mm, 1 psf = 47.9 Pa, 1 inch = 25.4 mm.

<sup>1</sup> The allowable load is the lowest value from the panel strength, stiffness and connection for each condition.

<sup>2</sup> For unequal multiple spans, the maximum span must be used to determine the allowable pressure from this table.

<sup>3</sup> See Figure 4 for details of Metl-Span fastening patterns.

**Table 2: Maximum Allowable Wind Pressure for Metl-Span CF Composite Foam Wall Panel<sup>1,2</sup>**

Panel Thickness: 2 inches  
 Panel Width: 30 inches (CF-30) or 36 inches (CF-36)  
 Fascia/Liner Profile: Architectural/Mesa  
 Fascia/Liner Steel Thickness: 22/26

Span (feet)	No of Spans	Allowable Negative and Positive Wind Pressure (psf)							
		Panel Stiffness and Strength		Panel Connection Strength <sup>3</sup>					
		L/180	Strength	Pattern 1		Pattern 2		Pattern 3	
				CF-30	CF-36	CF-30	CF-36	CF-30	CF-36
5	1	100.8	79.1	43.1	35.9	63.7	53.1	86.2	71.8
	2	106.1	71.4	48.3	40.2	71.4	59.5	91.9	76.6
	3	107.3	70.0	49.5	41.3	73.3	61.1	95.6	79.6
6	1	77.5	65.9	35.9	29.9	53.1	44.2	71.8	59.8
	2	84.2	58.3	41.3	34.4	61.0	50.9	75.1	62.6
	3	85.1	57.5	42.0	35.0	62.2	51.8	79.1	65.9
7	1	60.9	56.5	30.8	25.6	45.5	37.9	61.6	51.3
	2	68.6	49.2	36.2	30.1	53.5	44.6	63.3	52.7
	3	69.1	48.8	36.5	30.4	54.0	45.0	67.4	56.2
8	1	48.5	49.5	26.9	22.4	39.8	33.2	53.9	44.9
	2	57.1	42.5	32.2	26.9	47.4	39.5	54.6	45.5
	3	57.1	42.4	32.3	26.9	47.7	39.8	58.8	49.0
9	1	39.2	40.6	23.9	19.9	35.4	29.5	47.9	39.9
	2	48.1	37.3	28.8	24.0	41.6	34.7	48.0	40.0
	3	47.8	37.5	28.9	24.1	42.7	35.6	52.1	43.4
10	1	32.0	32.9	21.5	17.9	31.9	26.5	43.1	35.9
	2	41.0	33.3	25.7	21.4	37.2	31.0	42.9	35.7
	3	40.4	33.6	26.2	21.8	38.7	32.2	46.8	39.0
11	1	26.4	27.2	19.6	16.3	29.0	24.1	39.2	32.6
	2	35.3	30.1	23.2	19.3	33.5	27.9	38.7	32.2
	3	34.4	30.5	23.9	19.9	35.3	29.4	42.5	35.4
12	1	22.0	22.9	17.9	15.0	26.5	22.1	35.9	29.9
	2	30.6	27.4	21.1	17.6	30.6	25.5	35.3	29.4
	3	29.5	27.9	22.0	18.3	32.5	27.1	38.9	32.4

For SI: 1 foot = 305 mm, 1 psf = 47.9 Pa, 1 inch = 25.4 mm.

<sup>1</sup> The allowable load is the lowest value from the panel strength, stiffness and connection for each condition.

<sup>2</sup> For unequal multiple spans, the maximum span must be used to determine the allowable pressure from this table.

<sup>3</sup> See Figure 4 for details of Metl-Span fastening patterns.

**Table 3: Maximum Allowable Wind Pressure for Metl-Span CF Composite Foam Wall Panel<sup>1,2</sup>**

Panel Thickness: 2 inches  
 Panel Width: 42 inches (CF-42)  
 Fascia/Liner Profile: Mesa/Mesa Or Flute/Mesa  
 Fascia/Liner Steel Thickness: 26/26

Span (feet)	No of Spans	Allowable Negative and Positive Wind Pressure (psf)				
		Panel Stiffness and Strength		Panel Connection Strength <sup>3</sup>		
		L/180	Strength	Pattern 1	Pattern 2	Pattern 3
5	1	92.1	75.9	29.6	44.3	60.4
	2	98.8	67.6	33.7	50.5	63.4
	3	99.9	66.5	34.5	51.6	66.4
6	1	69.7	63.3	24.7	37.0	50.3
	2	77.8	55.3	28.8	43.2	51.7
	3	78.5	54.8	29.2	43.7	55.0
7	1	53.9	54.2	21.1	31.7	43.1
	2	63.0	46.6	25.3	37.7	43.7
	3	63.1	46.5	25.3	37.9	46.9
8	1	42.4	43.2	18.5	27.7	37.7
	2	52.0	40.3	22.3	32.6	37.7
	3	51.6	40.5	22.3	33.5	40.9
9	1	33.8	34.2	16.4	24.6	33.6
	2	43.5	35.5	19.6	28.7	33.2
	3	42.7	35.8	20.0	29.9	36.3
10	1	27.3	27.7	14.8	22.2	30.2
	2	36.8	31.7	17.5	25.6	29.7
	3	35.7	32.1	18.1	27.1	32.6
11	1	22.2	22.9	13.5	20.2	27.5
	2	31.4	27.8	15.8	23.2	26.8
	3	30.1	29.1	16.5	24.7	29.6
12	1	18.3	19.2	12.3	18.5	25.2
	2	27.0	22.7	14.4	21.1	24.4
	3	25.6	25.8	15.2	22.7	27.1

For SI: 1 foot = 305 mm, 1 psf = 47.9 Pa, 1 inch = 25.4 mm.

<sup>1</sup> The allowable load is the lowest value from the panel strength, stiffness and connection for each condition.

<sup>2</sup> For unequal multiple spans, the maximum span must be used to determine the allowable pressure from this table.

<sup>3</sup> See Figure 4 for details of Metl-Span fastening patterns.

**Table 4: Maximum Allowable Wind Pressure for Metl-Span CF Composite Foam Wall Panel<sup>1,2</sup>**

Panel Thickness: 2.5 inches  
 Panel Width: 30 inches (CF-30) or 36 inches (CF-36)  
 Fascia/Liner Profile: Mesa/Mesa  
 Fascia/Liner Steel Thickness: 26/26

Span (feet)	No of Spans	Allowable Negative and Positive Wind Pressure (psf)							
		Panel Stiffness and Strength		Panel Connection Strength <sup>3</sup>					
		I/180	Strength	Pattern 1		Pattern 2		Pattern 3	
				CF-30	CF-36	CF-30	CF-36	CF-30	CF-36
5	1	120.1	87.7	47.5	39.6	68.1	56.8	90.6	75.5
	2	125.9	79.4	53.1	44.2	76.1	63.4	97.9	81.6
	3	127.3	77.7	54.5	45.4	78.2	65.2	101.6	84.7
6	1	92.6	73.1	39.6	33.0	56.8	47.3	75.5	62.9
	2	100.1	64.8	45.4	37.8	65.1	54.2	79.9	66.6
	3	101.2	63.9	46.3	38.6	66.4	55.3	84.0	70.0
7	1	72.9	62.6	33.9	28.3	48.7	40.6	64.7	53.9
	2	81.7	54.6	39.8	33.1	57.0	47.5	67.4	56.1
	3	82.4	54.2	40.2	33.5	57.7	48.1	71.6	59.7
8	1	58.3	54.8	29.7	24.7	42.6	35.5	56.6	47.2
	2	68.0	47.2	35.4	29.5	50.8	42.4	58.1	48.5
	3	68.2	47.1	35.5	29.6	51.0	42.5	62.4	52.0
9	1	47.2	46.9	26.4	22.0	37.9	31.5	50.3	42.0
	2	57.4	41.5	31.8	26.5	44.7	37.3	51.1	42.6
	3	57.1	41.6	31.8	26.5	45.7	38.0	55.3	46.1
10	1	38.7	38.0	23.8	19.8	34.1	28.4	45.3	37.8
	2	49.1	37.0	28.4	23.7	39.9	33.2	45.6	38.0
	3	48.4	37.3	28.8	24.0	41.3	34.4	49.7	41.4
11	1	32.0	31.4	21.6	18.0	31.0	25.8	41.2	34.3
	2	42.3	33.4	25.6	21.4	36.0	30.0	41.1	34.3
	3	41.3	33.8	26.3	21.9	37.8	31.5	45.1	37.6
12	1	26.7	26.4	19.8	16.5	28.4	23.7	37.8	31.5
	2	36.7	30.4	23.4	19.5	32.8	27.3	37.5	31.2
	3	35.4	30.9	24.2	20.2	34.7	28.9	41.3	34.4

For SI: 1 foot = 305 mm, 1 psf = 47.9 Pa, 1 inch = 25.4 mm.

<sup>1</sup> The allowable load is the lowest value from the panel strength, stiffness and connection for each condition.

<sup>2</sup> For unequal multiple spans, the maximum span must be used to determine the allowable pressure from this table.

<sup>3</sup> See Figure 4 for details of Metl-Span fastening patterns.

**Table 5: Maximum Allowable Wind Pressure for Metl-Span CF Composite Foam Wall Panel<sup>1,2</sup>**

Panel Thickness: 2.5 inches  
 Panel Width: 30 inches (CF-30) or 36 inches (CF-36)  
 Fascia/Liner Profile: Architectural/Mesa  
 Fascia/Liner Steel Thickness: 22/26

Span (feet)	No of Spans	Allowable Negative and Positive Wind Pressure (psf)							
		Panel Stiffness and Strength		Panel Connection Strength <sup>3</sup>					
		I/180	Strength	Pattern 1		Pattern 2		Pattern 3	
				CF-30	CF-36	CF-30	CF-36	CF-30	CF-36
5	1	127.5	89.4	48.8	40.7	69.5	57.9	92.0	76.6
	2	131.8	82.0	53.7	44.8	76.4	63.7	100.9	84.1
	3	133.2	80.0	55.3	46.1	78.7	65.6	103.9	86.6
6	1	99.6	74.5	40.7	33.9	57.9	48.2	76.6	63.9
	2	105.4	67.0	45.9	38.2	65.2	54.4	82.4	68.7
	3	106.6	65.7	47.0	39.2	66.9	55.7	85.9	71.6
7	1	79.6	63.9	34.9	29.1	49.6	41.4	65.7	54.7
	2	86.6	56.4	40.2	33.5	57.2	47.6	69.4	57.9
	3	87.5	55.7	40.9	34.1	58.2	48.5	73.2	61.0
8	1	64.5	55.9	30.5	25.4	43.4	36.2	57.5	47.9
	2	72.6	48.7	35.8	29.9	51.0	42.5	59.9	49.9
	3	73.1	48.3	36.2	30.2	51.5	42.9	63.8	53.1
9	1	52.9	49.6	27.1	22.6	38.6	32.2	51.1	42.6
	2	61.7	42.8	32.4	27.0	46.1	38.4	52.6	43.8
	3	61.9	42.7	32.5	27.1	46.2	38.5	56.5	47.1
10	1	43.9	40.1	24.4	20.3	34.7	28.9	46.0	38.3
	2	53.1	38.1	29.5	24.6	41.1	34.2	46.9	39.1
	3	52.9	38.2	29.4	24.5	41.9	34.9	50.7	42.2
11	1	36.7	33.2	22.2	18.5	31.6	26.3	41.8	34.8
	2	46.1	34.4	26.6	22.2	37.1	30.9	42.3	35.2
	3	45.5	34.6	26.9	22.4	38.3	31.9	46.0	38.3
12	1	30.9	27.9	20.3	17.0	28.9	24.1	38.3	31.9
	2	40.3	31.3	24.2	20.2	33.7	28.1	38.5	32.1
	3	39.5	31.6	24.8	20.6	35.2	29.4	42.1	35.1

For SI: 1 foot = 305 mm, 1 psf = 47.9 Pa, 1 inch = 25.4 mm.

<sup>1</sup> The allowable load is the lowest value from the panel strength, stiffness and connection for each condition.

<sup>2</sup> For unequal multiple spans, the maximum span must be used to determine the allowable pressure from this table.

<sup>3</sup> See Figure 4 for details of Metl-Span fastening patterns.



**Table 6: Maximum Allowable Wind Pressure for Metl-Span CF Composite Foam Wall Panel<sup>1,2</sup>**

Panel Thickness: 2.5 inches  
 Panel Width: 42 inches (CF-42)  
 Fascia/Liner Profile: Mesa/Mesa Or Flute/Mesa  
 Fascia/Liner Steel Thickness: 26/26

Span (feet)	No of Spans	Allowable Negative and Positive Wind Pressure (psf)				
		Panel Stiffness and Strength		Panel Connection Strength <sup>3</sup>		
		L/180	Strength	Pattern 1	Pattern 2	Pattern 3
5	1	118.9	86.6	33.8	48.5	64.6
	2	124.5	78.4	37.7	54.2	69.8
	3	125.9	76.7	38.7	55.7	72.4
6	1	91.7	72.1	28.2	40.4	53.8
	2	99.0	64.0	32.2	46.3	57.0
	3	100.1	63.1	32.9	47.2	59.9
7	1	72.3	61.8	24.1	34.7	46.1
	2	80.9	54.0	28.2	40.6	48.0
	3	81.5	53.5	28.6	41.0	51.1
8	1	57.9	54.1	21.1	30.3	40.4
	2	67.3	46.6	25.2	36.2	41.5
	3	67.5	46.5	25.3	36.3	44.5
9	1	46.9	44.7	18.8	27.0	35.9
	2	56.9	40.9	22.7	31.9	36.4
	3	56.6	41.1	22.6	32.5	39.4
10	1	38.5	36.2	16.9	24.3	32.3
	2	48.6	36.5	20.2	28.4	32.5
	3	48.0	36.8	20.5	29.4	35.4
11	1	31.8	29.9	15.4	22.1	29.4
	2	41.9	33.0	18.2	25.6	29.3
	3	41.0	33.4	18.7	26.9	32.1
12	1	26.6	25.1	14.1	20.2	26.9
	2	36.4	30.0	16.6	23.4	26.7
	3	35.2	30.5	17.2	24.7	29.4

For SI: 1 foot = 305 mm, 1 psf = 47.9 Pa, 1 inch = 25.4 mm.

<sup>1</sup> The allowable load is the lowest value from the panel strength, stiffness and connection for each condition.

<sup>2</sup> For unequal multiple spans, the maximum span must be used to determine the allowable pressure from this table.

<sup>3</sup> See Figure 4 for details of Metl-Span fastening patterns.

**Table 7: Maximum Allowable Wind Pressure for Metl-Span CF Composite Foam Wall Panel<sup>1,2</sup>**

Panel Thickness: 3 inches  
 Panel Width: 30 inches (CF-30) or 36 inches (CF-36)  
 Fascia/Liner Profile: Mesa/Mesa  
 Fascia/Liner Steel Thickness: 26/26

Span (feet)	No of Spans	Allowable Negative and Positive Wind Pressure (psf)							
		Panel Stiffness and Strength		Panel Connection Strength <sup>3</sup>					
		L/180	Strength	Pattern 1		Pattern 2		Pattern 3	
				CF-30	CF-36	CF-30	CF-36	CF-30	CF-36
5	1	144.3	97.1	52.8	44.0	73.4	61.2	95.9	79.9
	2	149.2	89.1	58.0	48.3	80.7	67.2	105.4	87.8
	3	150.7	86.9	59.8	49.8	83.1	69.3	108.6	90.5
6	1	112.8	80.9	44.0	36.6	61.2	51.0	79.9	66.6
	2	119.3	72.8	49.5	41.3	68.9	57.4	86.6	72.2
	3	120.7	71.3	50.8	42.3	70.6	58.9	90.3	75.2
7	1	90.1	69.4	37.7	31.4	52.4	43.7	68.5	57.1
	2	98.1	61.3	43.4	36.1	60.3	50.3	73.0	60.8
	3	99.1	60.5	44.2	36.8	61.5	51.2	76.9	64.1
8	1	73.1	60.7	33.0	27.5	45.9	38.2	59.9	49.9
	2	82.2	52.9	38.7	32.2	53.8	44.9	62.9	52.5
	3	82.8	52.5	39.1	32.6	54.4	45.3	67.0	55.8
9	1	60.0	52.8	29.3	24.4	40.8	34.0	53.3	44.4
	2	69.9	46.4	35.0	29.1	48.6	40.5	55.3	46.1
	3	70.1	46.3	35.1	29.2	48.8	40.7	59.3	49.5
10	1	49.8	42.8	26.4	22.0	36.7	30.6	47.9	39.9
	2	60.1	41.4	31.9	26.6	43.5	36.2	49.3	41.0
	3	59.9	41.5	31.8	26.5	44.2	36.8	53.3	44.4
11	1	41.6	35.3	24.0	20.0	33.4	27.8	43.6	36.3
	2	52.2	37.3	28.7	24.0	39.2	32.7	44.4	37.0
	3	51.6	37.6	29.0	24.2	40.4	33.7	48.3	40.3
12	1	35.1	29.7	22.0	18.3	30.6	25.5	39.9	33.3
	2	45.7	34.0	26.2	21.8	35.7	29.7	40.4	33.7
	3	44.7	34.3	26.7	22.3	37.2	31.0	44.2	36.9

For SI: 1 foot = 305 mm, 1 psf = 47.9 Pa, 1 inch = 25.4 mm.

<sup>1</sup> The allowable load is the lowest value from the panel strength, stiffness and connection for each condition.

<sup>2</sup> For unequal multiple spans, the maximum span must be used to determine the allowable pressure from this table.

<sup>3</sup> See Figure 4 for details of Metl-Span fastening patterns.

**Table 8: Maximum Allowable Wind Pressure for Metl-Span CF Composite Foam Wall Panel<sup>1,2</sup>**

Panel Thickness: 3 inches  
 Panel Width: 30 inches (CF-30) or 36 inches (CF-36)  
 Fascia/Liner Profile: Architectural/Mesa  
 Fascia/Liner Steel Thickness: 22/26

Span (feet)	No of Spans	Allowable Negative and Positive Wind Pressure (psf)							
		Panel Stiffness and Strength		Panel Connection Strength <sup>3</sup>					
		L/180	Strength	Pattern 1		Pattern 2		Pattern 3	
				CF-30	CF-36	CF-30	CF-36	CF-30	CF-36
5	1	151.4	98.7	54.0	45.0	74.7	62.2	97.2	81.0
	2	154.9	91.6	58.6	48.8	80.9	67.4	105.3	87.7
	3	156.3	89.3	60.4	50.3	83.5	69.6	108.6	90.5
6	1	119.8	82.2	45.0	37.5	62.2	51.9	81.0	67.5
	2	124.6	74.9	49.9	41.6	69.0	57.5	89.1	74.3
	3	126.0	73.2	51.4	42.8	71.0	59.1	92.2	76.8
7	1	96.8	70.5	38.6	32.2	53.3	44.5	69.4	57.8
	2	103.0	63.1	43.7	36.4	60.4	50.3	75.1	62.6
	3	104.2	62.0	44.7	37.3	61.8	51.5	78.5	65.4
8	1	79.5	61.7	33.8	28.1	46.7	38.9	60.7	50.6
	2	86.8	54.4	39.0	32.5	53.8	44.9	64.7	54.0
	3	87.7	53.7	39.6	33.0	54.8	45.7	68.3	56.9
9	1	66.1	54.8	30.0	25.0	41.5	34.6	54.0	45.0
	2	74.2	47.8	35.2	29.4	48.7	40.6	56.8	47.4
	3	74.8	47.4	35.6	29.7	49.2	41.0	60.5	50.4
10	1	55.4	44.9	27.0	22.5	37.3	31.1	48.6	40.5
	2	64.2	42.5	32.2	26.8	44.5	37.1	50.6	42.2
	3	64.4	42.4	32.3	26.9	44.6	37.2	54.3	45.2
11	1	46.9	37.1	24.6	20.5	33.9	28.3	44.2	36.8
	2	56.1	38.3	29.6	24.7	40.3	33.6	45.6	38.0
	3	56.0	38.4	29.5	24.6	40.8	34.0	49.2	41.0
12	1	39.9	31.2	22.5	18.8	31.1	25.9	40.5	33.7
	2	49.4	34.8	27.1	22.6	36.7	30.6	41.5	34.5
	3	48.9	35.1	27.2	22.7	37.6	31.4	45.0	37.5

For SI: 1 foot = 305 mm, 1 psf = 47.9 Pa, 1 inch = 25.4 mm.

<sup>1</sup> The allowable load is the lowest value from the panel strength, stiffness and connection for each condition.

<sup>2</sup> For unequal multiple spans, the maximum span must be used to determine the allowable pressure from this table.

<sup>3</sup> See Figure 4 for details of Metl-Span fastening patterns.

**Table 9: Maximum Allowable Wind Pressure for Metl-Span CF Composite Foam Wall Panel<sup>1,2</sup>**

Panel Thickness: 3 inches  
 Panel Width: 42 inches (CF-42)  
 Fascia/Liner Profile: Mesa/Mesa Or Flute/Mesa  
 Fascia/Liner Steel Thickness: 26/26

Span (feet)	No of Spans	Allowable Negative and Positive Wind Pressure (psf)				
		Panel Stiffness and Strength		Panel Connection Strength <sup>3</sup>		
		L/180	Strength	Pattern 1	Pattern 2	Pattern 3
5	1	143.1	96.0	37.5	52.3	68.3
	2	147.8	88.2	41.2	57.4	75.0
	3	149.3	86.0	42.5	59.2	77.3
6	1	112.0	80.0	31.3	43.6	57.0
	2	118.3	72.0	35.2	49.0	61.8
	3	119.7	70.6	36.1	50.3	64.3
7	1	89.6	68.6	26.8	37.3	48.8
	2	97.3	60.7	30.8	42.9	52.0
	3	98.3	59.8	31.4	43.7	54.8
8	1	72.7	60.0	23.5	32.7	42.7
	2	81.5	52.3	27.5	38.3	44.9
	3	82.2	51.9	27.8	38.7	47.7
9	1	59.8	52.4	20.9	29.0	38.0
	2	69.4	46.0	24.8	34.6	39.4
	3	69.6	45.9	24.9	34.7	42.3
10	1	49.6	42.4	18.8	26.1	34.2
	2	59.7	41.0	22.7	31.0	35.1
	3	59.5	41.1	22.6	31.5	38.0
11	1	41.5	35.1	17.1	23.8	31.1
	2	51.9	36.9	20.5	27.9	31.7
	3	51.3	37.2	20.7	28.8	34.4
12	1	35.0	29.5	15.6	21.8	28.5
	2	45.4	33.6	18.6	25.4	28.8
	3	44.5	34.0	19.0	26.5	31.5

For SI: 1 foot = 305 mm, 1 psf = 47.9 Pa, 1 inch = 25.4 mm.

<sup>1</sup> The allowable load is the lowest value from the panel strength, stiffness and connection for each condition.

<sup>2</sup> For unequal multiple spans, the maximum span must be used to determine the allowable pressure from this table.

<sup>3</sup> See Figure 4 for details of Metl-Span fastening patterns.

Table 10: Maximum Allowable Wind Pressure for Metl-Span CF Composite Foam Wall Panel<sup>1,2</sup>

Panel Thickness: 4 inches  
 Panel Width: 42 inches (CF-42)  
 Fascia/Liner Profile: Mesa/Mesa Or Flute/Mesa  
 Fascia/Liner Steel Thickness: 26/26

Span (feet)	No of Spans	Allowable Negative and Positive Wind Pressure (psf)				
		Panel Stiffness and Strength		Panel Connection Strength <sup>3</sup>		
		L/180	Strength	Pattern 1	Pattern 2	Pattern 3
5	1	183.0	100.8	36.5	51.2	67.3
	2	186.1	94.5	39.1	54.9	67.0
	3	187.4	92.0	40.3	56.6	68.3
6	1	145.9	84.0	30.4	42.7	56.0
	2	150.3	77.3	32.5	46.7	54.9
	3	151.8	75.4	33.4	48.1	56.4
7	1	119.0	72.0	26.0	36.6	48.0
	2	124.7	65.2	27.4	40.0	46.3
	3	126.1	63.8	28.5	41.5	48.0
8	1	98.7	63.0	22.8	32.0	42.0
	2	105.5	56.2	23.6	34.5	39.9
	3	106.7	55.3	24.8	36.1	41.8
9	1	82.7	56.0	20.3	28.4	37.4
	2	90.7	49.3	20.7	30.3	35.0
	3	91.6	48.7	21.9	32.0	37.0
10	1	70.0	50.4	18.2	25.6	33.6
	2	78.8	43.9	18.5	26.9	31.1
	3	79.4	43.6	19.7	28.7	33.2
11	1	59.7	41.8	16.6	23.3	30.6
	2	69.1	39.5	16.6	24.2	28.0
	3	69.4	39.4	17.8	26.0	30.1
12	1	51.3	35.1	15.2	21.3	28.0
	2	61.1	35.9	15.1	22.0	25.5
	3	61.0	36.0	16.3	23.8	27.5
13	1	44.3	29.9	14.0	19.7	25.9
	2	54.4	32.9	13.8	20.2	23.4
	3	54.0	33.1	15.0	21.9	25.3
14	1	38.5	25.8	13.0	18.3	24.0
	2	48.7	30.4	12.8	18.6	21.6
	3	48.0	30.6	13.9	20.3	23.5
15	1	33.6	22.5	12.2	17.1	22.4
	2	43.7	28.2	11.9	17.3	20.0
	3	42.8	28.5	13.0	18.9	21.9
16	1	29.4	19.8	11.4	16.0	21.0
	2	39.5	25.0	11.1	16.1	18.7
	3	38.4	26.7	12.2	17.7	20.5

For SI: 1 foot = 305 mm, 1 psf = 47.9 Pa, 1 inch = 25.4 mm.

<sup>1</sup> The allowable load is the lowest value from the panel strength, stiffness and connection for each condition.

<sup>2</sup> For unequal multiple spans, the maximum span must be used to determine the allowable pressure from this table.

<sup>3</sup> See Figure 4 for details of Metl-Span fastening patterns.



Table 11: Maximum Allowable Wind Pressure for Metl-Span CF Composite Foam Wall Panel<sup>1,2</sup>

Panel Thickness: 5 inches  
 Panel Width: 42 inches (CF-42)  
 Fascia/Liner Profile: Mcsa/Mcsa Or Flute/Mcsa  
 Fascia/Liner Steel Thickness: 26/26

Span (feet)	No of Spans	Allowable Negative and Positive Wind Pressure (psf)				
		Panel Stiffness and Strength		Panel Connection Strength <sup>3</sup>		
		L/180	Strength	Pattern 1	Pattern 2	Pattern 3
5	1	210.6	113.8	36.5	51.2	67.3
	2	212.5	108.3	38.4	53.9	68.1
	3	213.5	105.6	39.5	55.5	68.8
6	1	170.0	94.8	30.4	42.7	56.0
	2	172.8	88.9	32.6	45.7	55.9
	3	174.1	86.5	33.6	47.2	56.9
7	1	140.5	81.3	26.0	36.6	48.0
	2	144.4	75.0	28.0	39.9	47.2
	3	145.7	73.2	28.7	41.1	48.4
8	1	118.1	71.1	22.8	32.0	42.0
	2	123.0	64.7	24.1	35.2	40.7
	3	124.3	63.3	25.0	36.4	42.1
9	1	100.4	63.2	20.3	28.4	37.4
	2	106.3	56.8	21.2	30.9	35.7
	3	107.5	55.7	22.1	32.2	37.2
10	1	86.2	56.9	18.2	25.6	33.6
	2	93.0	50.5	18.8	27.5	31.8
	3	94.1	49.7	19.8	28.8	33.4
11	1	74.6	51.7	16.6	23.3	30.6
	2	82.2	45.4	16.9	24.7	28.6
	3	83.0	44.9	17.9	26.1	30.2
12	1	65.0	44.9	15.2	21.3	28.0
	2	73.2	41.3	15.4	22.4	25.9
	3	73.7	41.0	16.4	23.9	27.6
13	1	56.9	38.3	14.0	19.7	25.9
	2	65.6	37.8	14.1	20.5	23.8
	3	65.8	37.7	15.1	22.0	25.4
14	1	50.0	33.0	13.0	18.3	24.0
	2	59.1	34.8	13.0	18.9	21.9
	3	59.1	34.8	14.0	20.4	23.6
15	1	44.2	28.8	12.2	17.1	22.4
	2	53.5	32.3	12.0	17.6	20.3
	3	53.3	32.4	13.0	19.0	22.0
16	1	39.2	25.3	11.4	16.0	21.0
	2	48.6	30.1	11.2	16.4	18.9
	3	48.2	30.3	12.2	17.8	20.6

For SI: 1 foot = 305 mm, 1 psf = 47.9 Pa, 1 inch = 25.4 mm.

<sup>1</sup> The allowable load is the lowest value from the panel strength, stiffness and connection for each condition.

<sup>2</sup> For unequal multiple spans, the maximum span must be used to determine the allowable pressure from this table.

<sup>3</sup> See Figure 4 for details of Metl-Span fastening patterns.

**Table 12: Maximum Allowable Wind Pressure for Metl-Span CF Composite Foam Wall Panel<sup>1,2</sup>**

Panel Thickness: 6 inches  
 Panel Width: 42 inches (CF-42)  
 Fascia/Liner Profile: Mesa/Mesa Or Flute/Mesa  
 Fascia/Liner Steel Thickness: 26/26

Span (feet)	No of Spans	Allowable Negative and Positive Wind Pressure (psf)				
		Panel Stiffness and Strength		Panel Connection Strength <sup>3</sup>		
		L/180	Strength	Pattern 1	Pattern 2	Pattern 3
5	1	225.5	125.4	36.5	51.2	67.3
	2	226.7	120.7	37.9	53.3	68.9
	3	227.4	118.0	38.9	54.6	69.3
6	1	183.6	104.5	30.4	42.7	56.0
	2	185.3	99.3	32.0	45.0	56.7
	3	186.3	96.8	33.0	46.3	57.3
7	1	153.2	89.6	26.0	36.6	48.0
	2	155.6	84.0	27.9	39.1	47.9
	3	156.7	81.8	28.8	40.4	48.8
8	1	130.0	78.4	22.8	32.0	42.0
	2	133.3	72.6	24.5	34.8	41.4
	3	134.4	70.7	25.1	35.9	42.4
9	1	111.8	69.7	20.3	28.4	37.4
	2	115.8	63.7	21.6	31.4	36.4
	3	117.0	62.2	22.2	32.3	37.5
10	1	97.1	62.7	18.2	25.6	33.6
	2	101.9	56.7	19.2	28.0	32.3
	3	103.0	55.5	19.9	29.0	33.6
11	1	84.9	57.0	16.6	23.3	30.6
	2	90.4	51.0	17.3	25.2	29.1
	3	91.5	50.1	18.0	26.3	30.4
12	1	74.8	52.2	15.2	21.3	28.0
	2	80.9	46.3	15.7	22.8	26.4
	3	81.8	45.6	16.5	24.0	27.8
13	1	66.2	46.7	14.0	19.7	25.9
	2	72.9	42.4	14.3	20.9	24.2
	3	73.6	41.9	15.2	22.1	25.6
14	1	58.9	40.3	13.0	18.3	24.0
	2	66.0	39.0	13.2	19.3	22.3
	3	66.6	38.7	14.0	20.5	23.7
15	1	52.5	35.1	12.2	17.1	22.4
	2	60.1	36.2	12.2	17.8	20.6
	3	60.4	36.0	13.1	19.1	22.1
16	1	47.0	30.8	11.4	16.0	21.0
	2	55.0	33.7	11.4	16.6	19.2
	3	55.1	33.6	12.2	17.9	20.6

For SI: 1 foot = 305 mm, 1 psf = 47.9 Pa, 1 inch = 25.4 mm.

<sup>1</sup> The allowable load is the lowest value from the panel strength, stiffness and connection for each condition.

<sup>2</sup> For unequal multiple spans, the maximum span must be used to determine the allowable pressure from this table.

<sup>3</sup> See Figure 4 for details of Metl-Span fastening patterns.

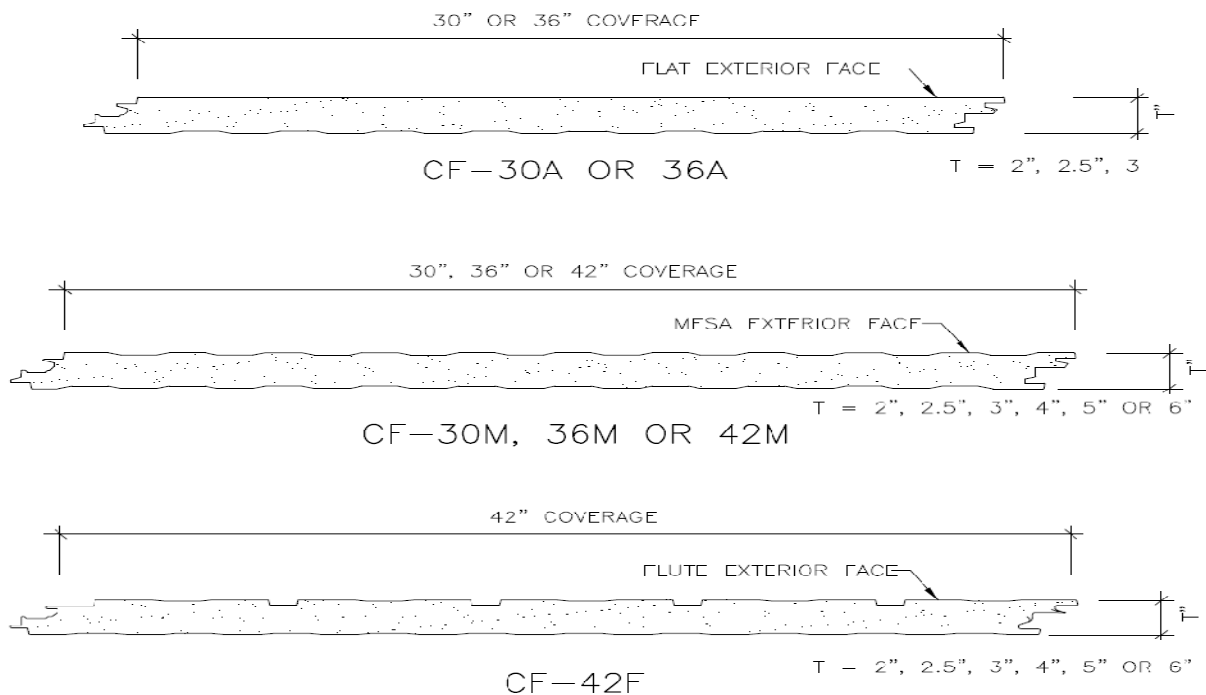

**FIGURE 1—PANEL PROFILES**

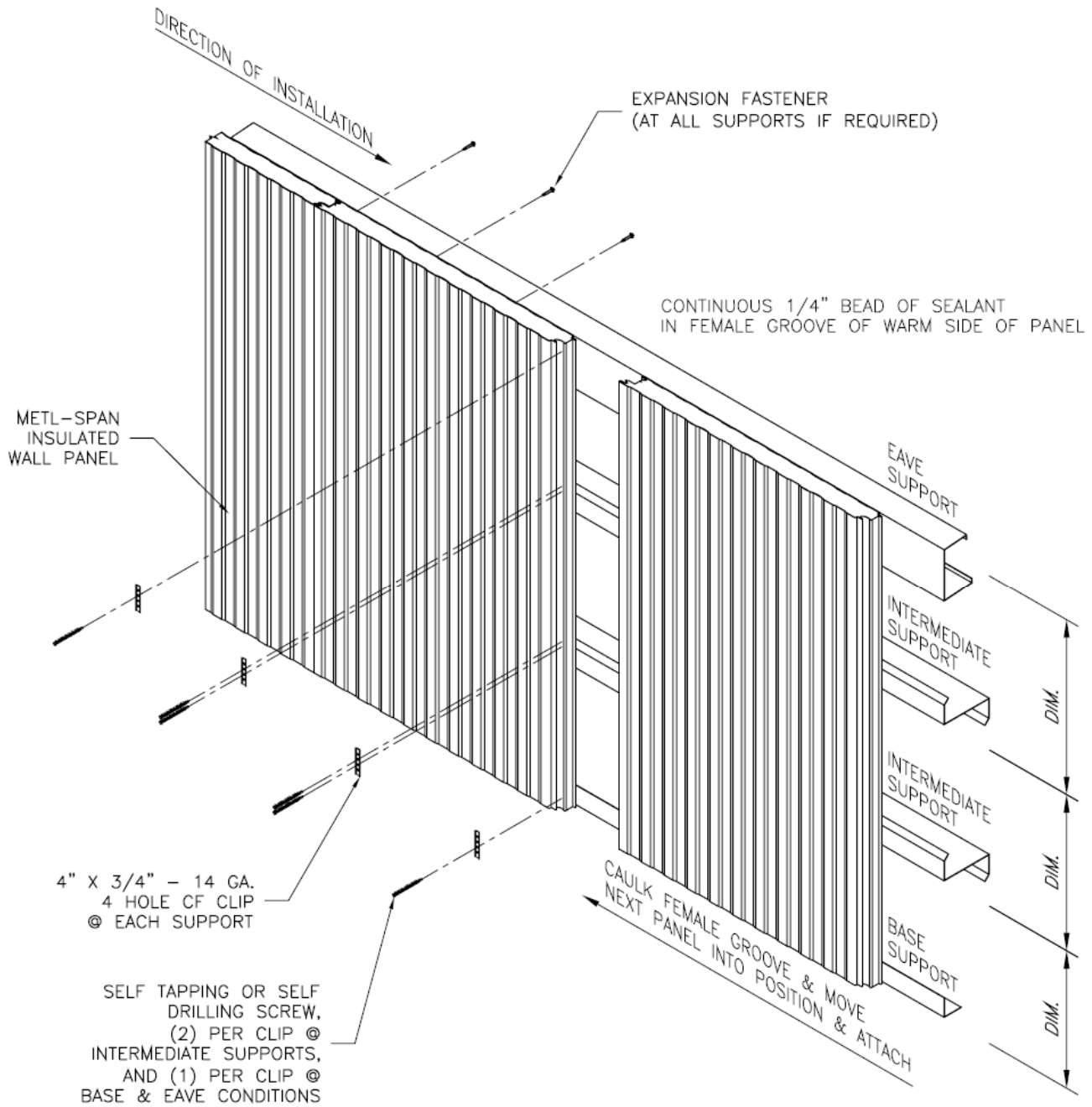
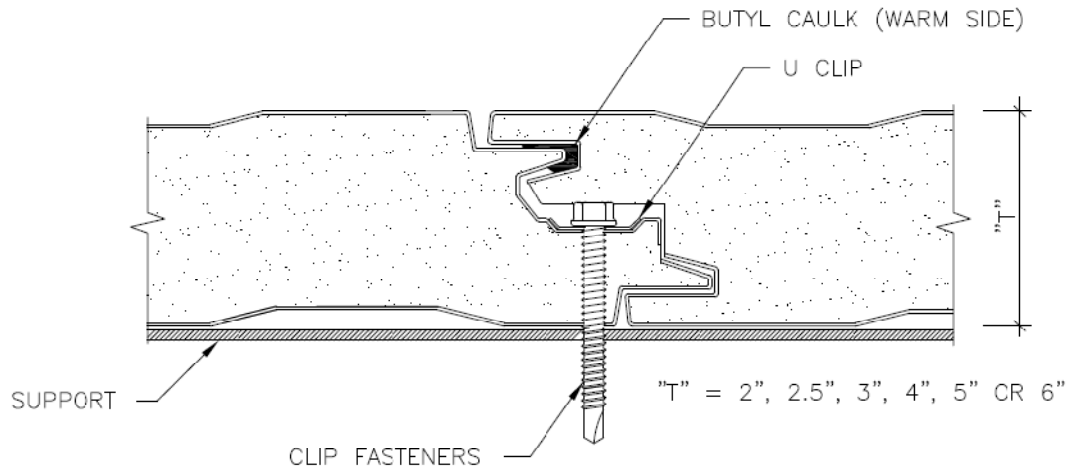

FIGURE 2—TYPICAL WALL INSTALLATION



CF PANEL SIDELAP

FIGURE 3—TYPICAL JOINT DETAILS

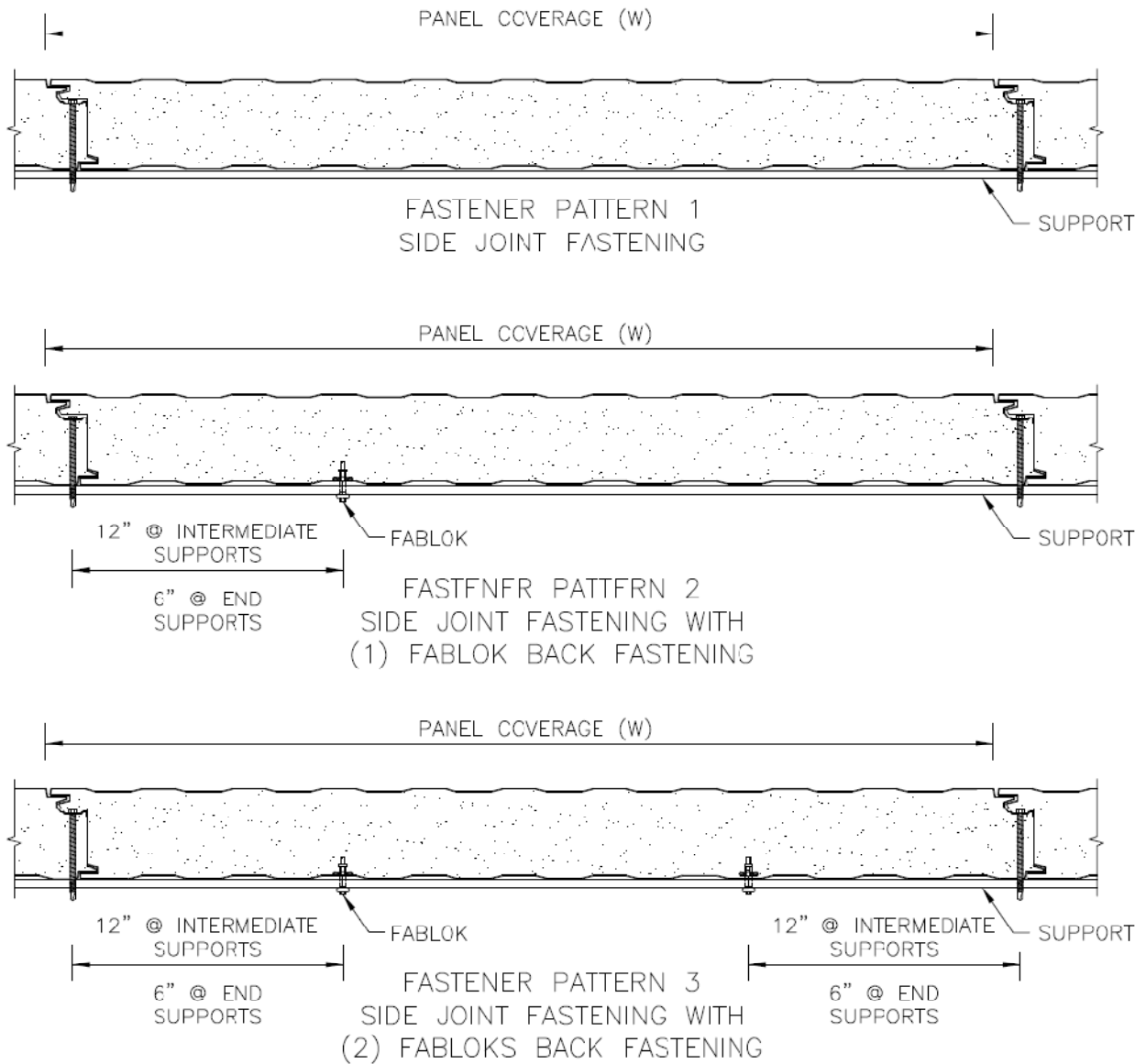

FIGURE 4—FASTENING PATTERNS FOR CF PANELS